

F5220

For: F2260, F2560, F3060, F3560, F2880, F2880E, F3680
 requires F5212 quick hitch and F5216 hose kit

For: * F2000, F2100, F2400 requires F5211 quick hitch
 and F5215 hose kit

FEATURES:

- F5220 is a new design 51 inch commercial snowblower with gearbox reduction
- Female quick hitch
- Complete driveline
- Heavy duty chute
- Chute rotation using a high torque, low speed motor "gear to gear" with chute
- raised chute base design to prevent buildup of ice
- Heavy duty chute retaining brackets
- 2 keyway design on output shaft of gear reduction box for increased durability

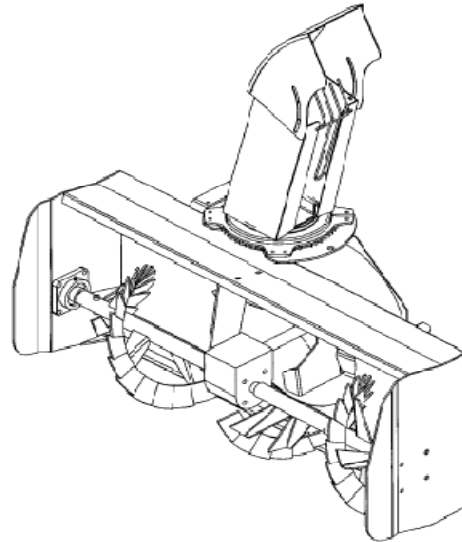

SPECIFICATIONS		
Overall length	in (mm)	29
Overall width	in (mm)	51 1/8
Overall height	in (mm)	23.5
Cutting width	in (mm)	51
Cutting height	in (mm)	22 1/8
Frame thickness		12 gauge
Side thickness	in (mm)	3/16"
Impeller back housing thickness		12 gauge
Impeller side housing thickness		12 gauge
Number of phases		2
Primary drive		PTO
Auger & impeller drive worm gear box ratio		5:1 + Reduction gearbox 3.58:1
Auger diameter	in (mm)	13.75
Auger pitch	in (mm)	16 1/8
Impeller diameter	in (mm)	17.75
Number of blades on impeller		4
Chute position		right
Chute rotation		Hydraulic
Adjustable chute deflector		Yes, manual, electric or hydraulic
Adjustable rear skid shoes		Yes
Replaceable cutting edge		Yes
Number of shear bolts on auger		2
Number of shear bolts on impeller		1
Hitch system		Quick hitch cat. B
Approximate weight	lbs (kg)	390

